

	1	2	3	4	5
No.	NAME	MATERIAL	DWG/MATL No.	CODE Q'TY	SIZE WEIGHT REMARK
				0	

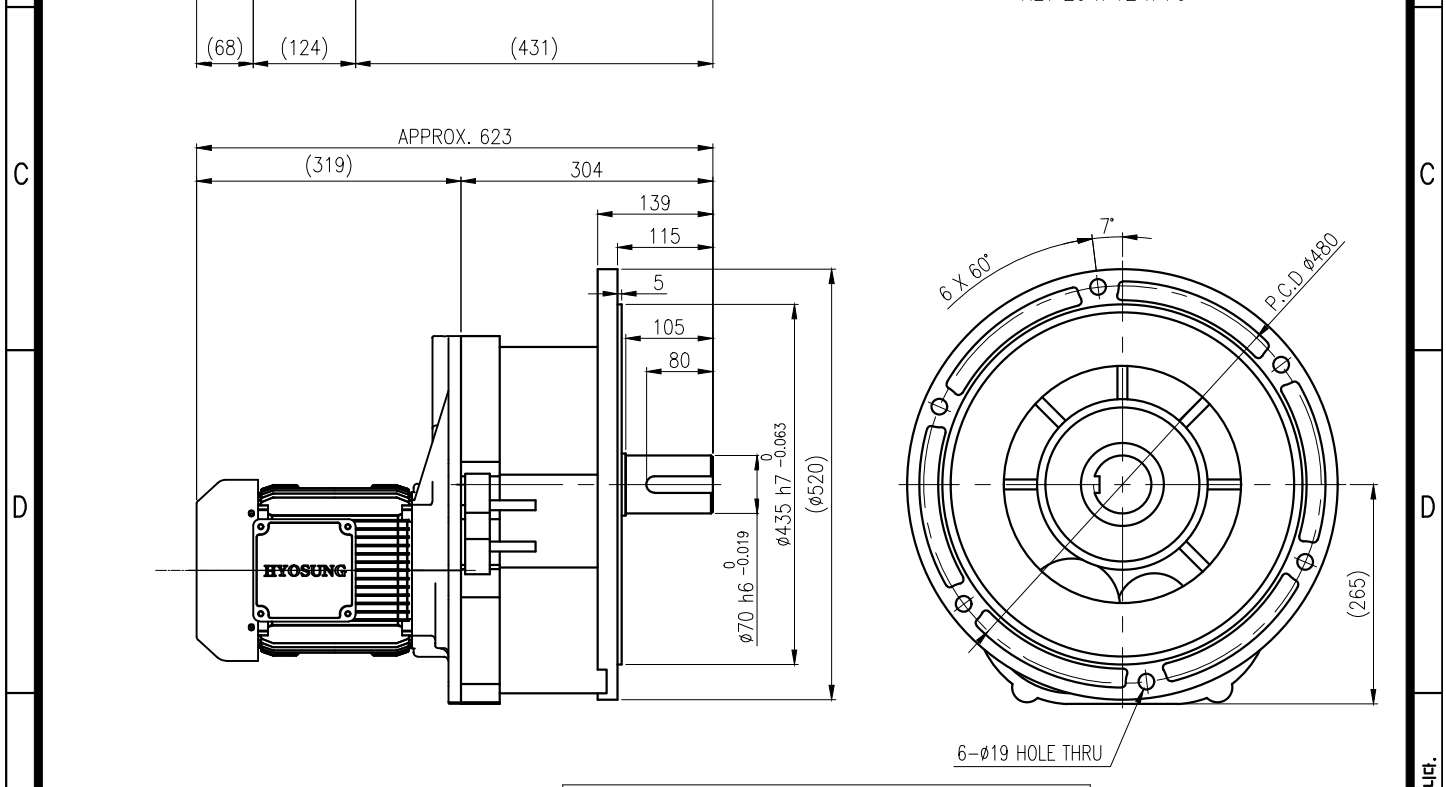
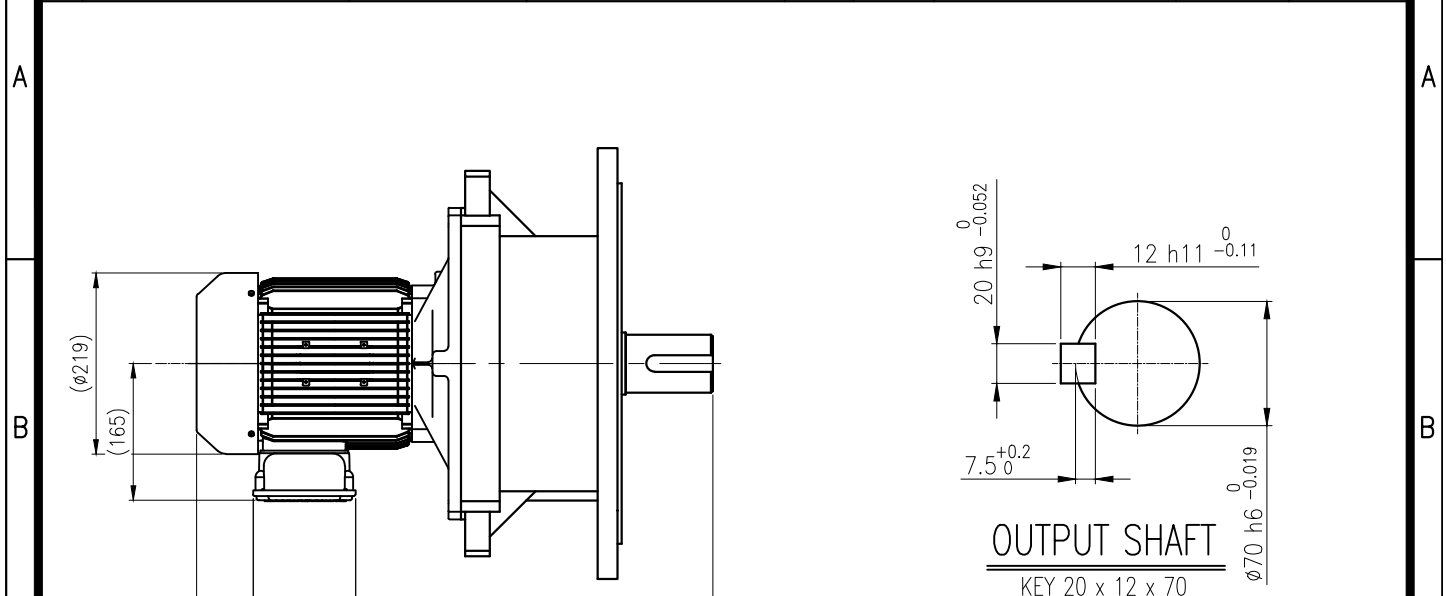

		BEARING			
		INPUT SHAFT	6205ZZ	6207ZZ	
OIL SEAL		2ND PINION	6305ZZ	6306ZZ	GREASE : NLGI(EP)00
MOTOR SHAFT	D(M) 35 x 47 x 7	3RD PINION	6307ZZ	6308ZZ	ABOUT 8.9 kg
OUTPUT SHAFT	D(M) 75 x 100 x 13	OUTPUT SHAFT	6311ZZ	21315	WEIGHT 173 kg

		DWG NAME				외형도 OUTLINE DIMENSION	
		DWG No.				UNIT	mm
		EY2D0100778H0001				SCALE	1:1
No.	DATE	DESIGNER		CHECKED	REVIEWED	APPROVED	DATE
		KIM.S.M		KIM.S.M	JUNG.S.S	JUNG.C.S	2024-02-06
DESCRIPTION of REVISION		REVISION No.		00			
TYPE		F1VA_27_2.2kW_100~120:1_프리미엄		THIRD ANGLE PROJECTION			
REF. No.		(EK2D007785H0001)				A	