

1	2	3	4	5				
No.	NAME	MATERIAL	DWG/MATL No.	CODE	Q'TY	SIZE	WEIGHT	REMARK
					0			

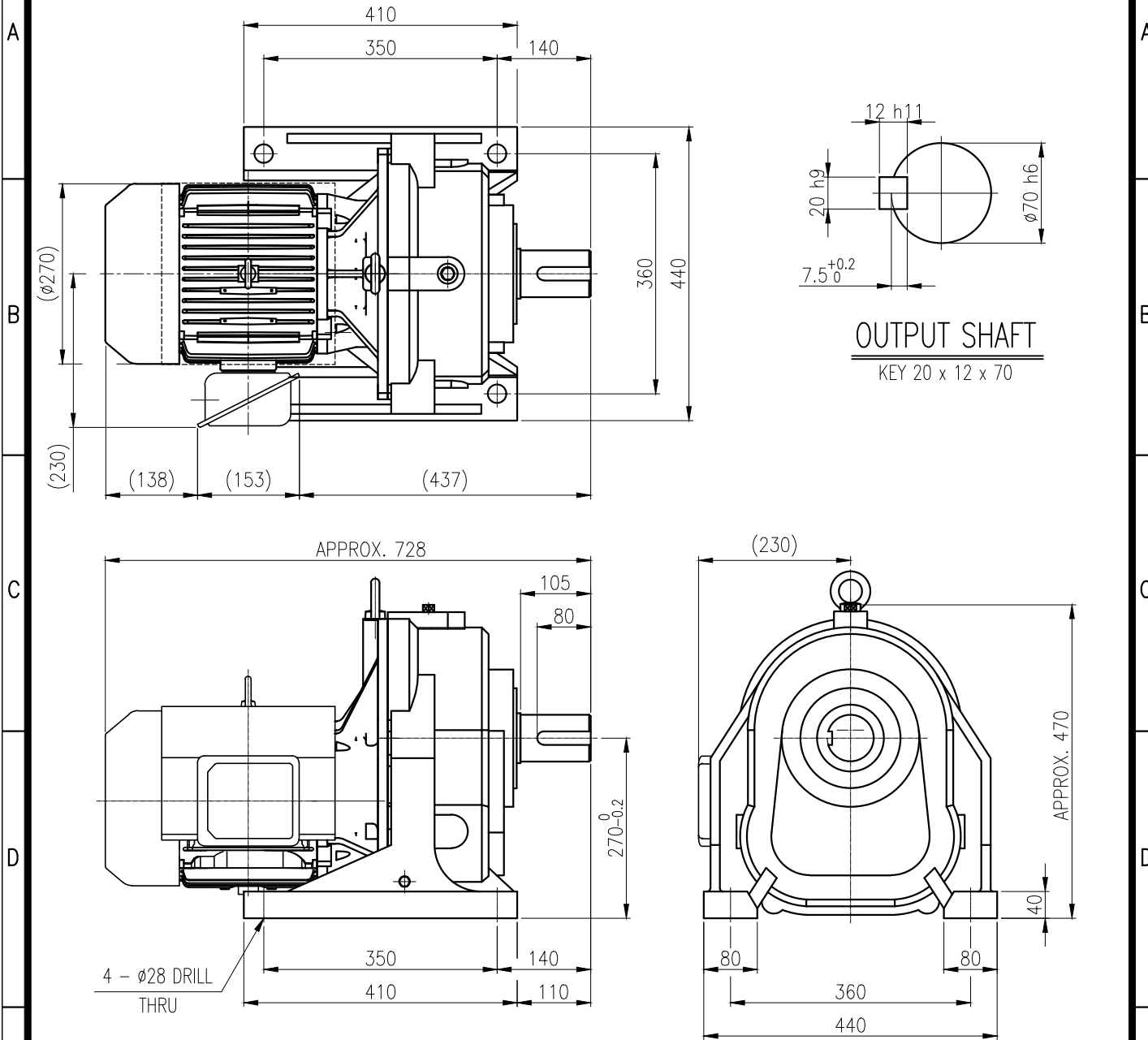

		BEARING			
		INPUT SHAFT	6207ZZ 6308ZZ		
OIL SEAL		2ND PINION	6306ZZ 6306ZZ	GREASE : NLGI(EP)00	
MOTOR SHAFT	D(M)40x62x11	3RD PINION	6307ZZ 6308ZZ	ABOUT	3.0 kg
OUTPUT SHAFT	D(M)75x100x13	OUTPUT SHAFT	6311ZZ 21315	WEIGHT	204 kg

		외형도 OUTLINE DIMENSION		DWG NAME	
		EYK2D008335W0001		UNIT	mm
				SCALE	1:1
No.	DATE	DESIGNED	CHECKED	REVIEWED	APPROVED
		KIM.H.U		HONG.W.C	JUNG.C.S
DESCRIPTION of REVISION		DATE	2021-08-25		
		REVISION No.	01		
		THIRD ANGLE PROJECTION			
TYPE F1HM_27_7.5kW_40~60:1_프리미엄		REF. No.	-		

The information written in this drawing is HYOSUNG HEAVY INDUSTRIES's property, and may not be disclosed and/or reproduced without the prior official permission of HYOSUNG HEAVY INDUSTRIES Corp.

이 도면상에 표시된 정보는 호성중공업(주)의 소유이며 당사의 사전 서면동의 없이 무단사용을 금합니다.