

1	2	3	4	5				
No.	NAME	MATERIAL	DWG/MATL No.	CODE	Q'TY	SIZE	WEIGHT	REMARK
					0			

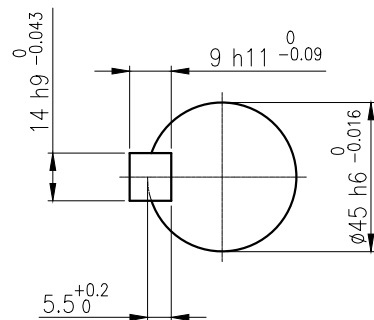

**OUTPUT SHAFT**  
KEY 14 x 9 x 68

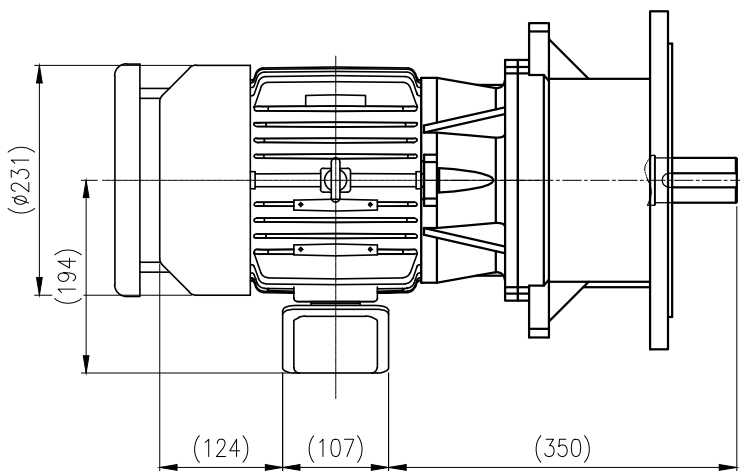
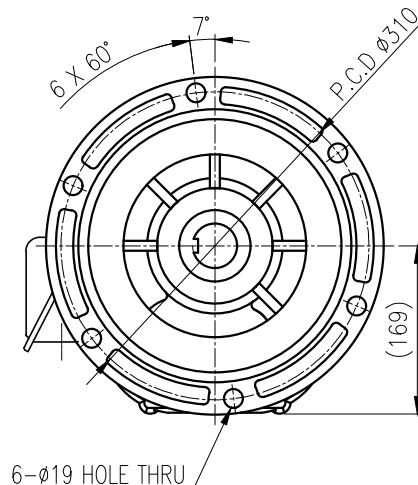
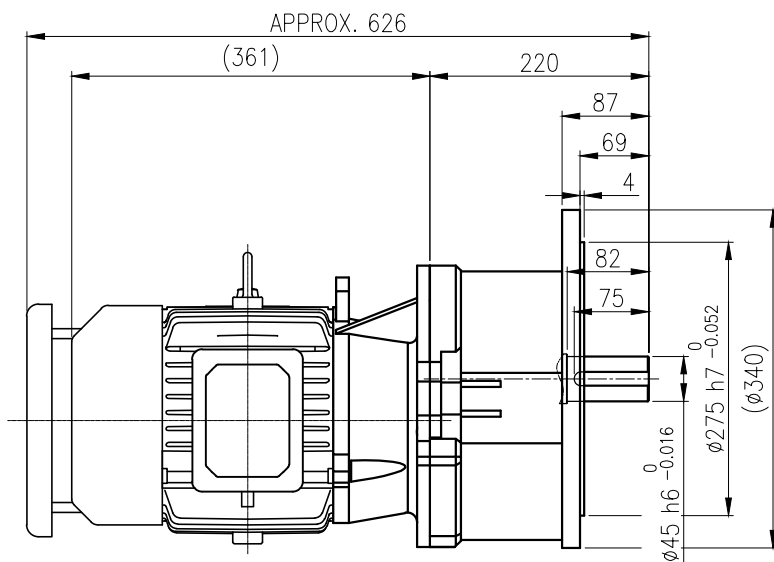

6-φ19 HOLE THRU

			BEARING		
			INPUT SHAFT	6206ZZ 6207ZZ	
			2ND PINION	6205ZZ 6305ZZ	GREASE : NLGI(EP)00
MOTOR SHAFT	D(M) 35 x 47 x 7	3RD PINION	-	-	ABOUT 3.0 kg
OUTPUT SHAFT	D(M) 50 x 72 x 12	OUTPUT SHAFT	PM3530 6310ZZ		WEIGHT 93 kg

		DWG NAME		외형도 OUTLINE DIMENSION			
		DWG No.		E K 2 D O 0 7 7 7 4 W 0 0 0 1		UNIT	mm
						SCALE	1:1
No.	DATE	DESCRIPTION of REVISION		DESIGNED	CHECKED	REVIEWED	APPROVED
				2019.05.30	2019.05.30	2019.05.30	2019.05.30
				김민정	문병선	박희성	홍원철
						DATE	2019-05-30
						REVISION No.	01
						THIRD ANGLE PROJECTION	
						REF. No.	-
						A	

이 도면상에 표시된 정보는 호성중공업(주)의 소유이며 당사의 사전 서면동의 없이 무단사용을 금합니다.