

1	2	3	4	5				
No.	NAME	MATERIAL	DWG/MATL No.	CODE	Q'TY	SIZE	WEIGHT	REMARK
					0			

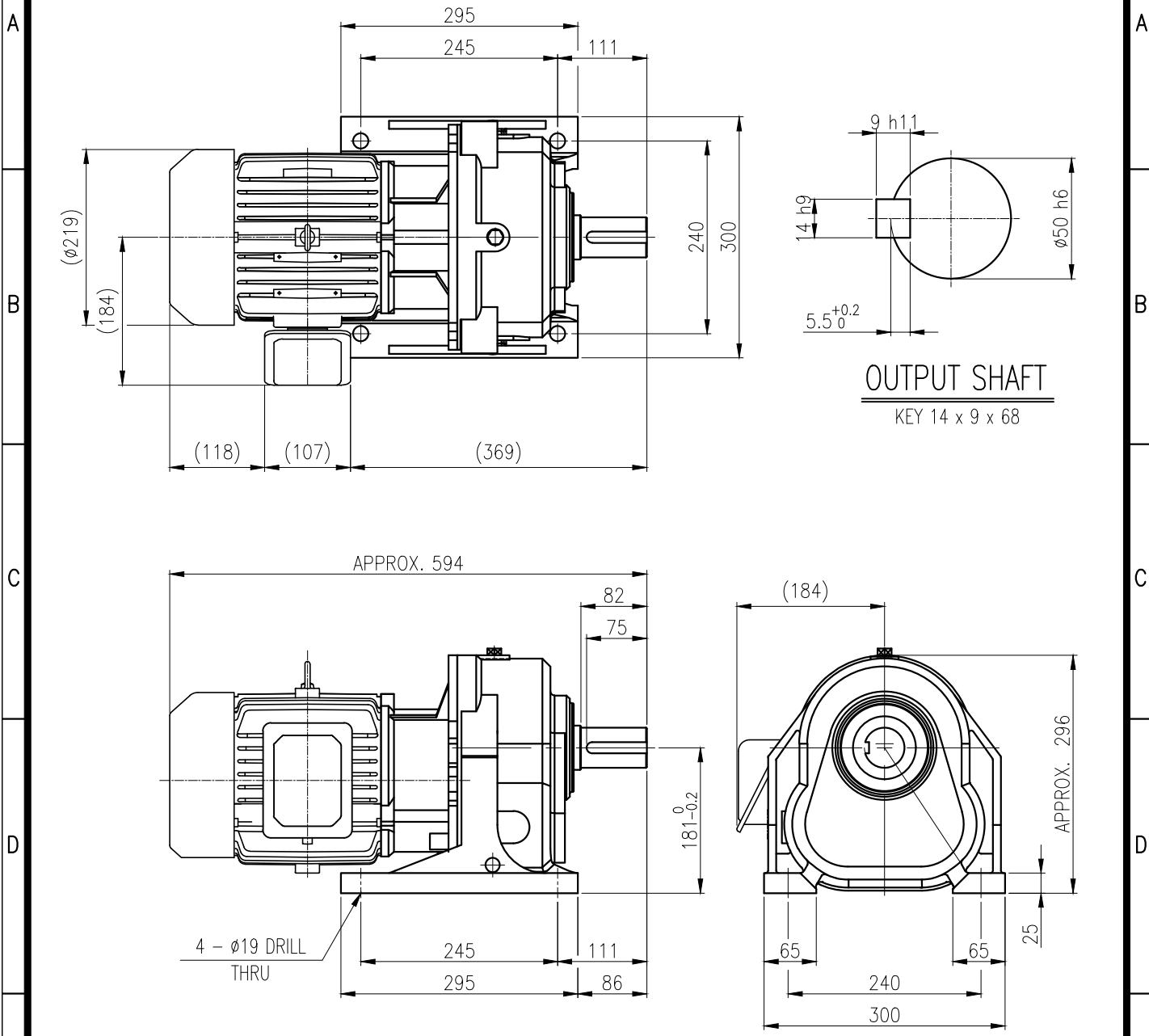

		BEARING			
		INPUT SHAFT	6205ZZ	6207ZZ	
OIL SEAL		2ND PINION	6204ZZ	6203ZZ	GREASE : NLGI(EP)00
MOTOR SHAFT	D(M) 35 x 47 x 7	3RD PINION	6206ZZ	6307ZZ	ABOUT 1.0 kg
OUTPUT SHAFT	D(M) 55 x 78 x 12	OUTPUT SHAFT	PM3530	22211	WEIGHT 90 kg

		DWG NAME		외형도 OUTLINE DIMENSION	
		DWG No.		E K2D007669H0001	
		UNIT		mm	
		SCALE		1:1	
No.	DATE	DESIGNED	CHECKED	REVIEWED	APPROVED
2019.01.21	2019.01.21	2019.01.21	2019.01.21	2019.01.21	2019.01.21
DESCRIPTION of REVISION		하슬기	문병선	박희성	홍원철
DATE		DATE		DATE	
2019-01-21		2019-01-21		2019-01-21	
REVISION No.		REVISION No.		REVISION No.	
01		01		01	
THIRD ANGLE PROJECTION		THIRD ANGLE PROJECTION		THIRD ANGLE PROJECTION	
TYPE		REF. No.		REF. No.	
F1HM_18_2.2W_40~100:1_프리미엄		-		-	

이 도면상에 표시된 정보는 호성중공업(주)의 소유이며 당사의 사전 서면동의 없이 무단사용을 금합니다.