

**OUTPUT SHAFT**  
(28 x 16 x 187)

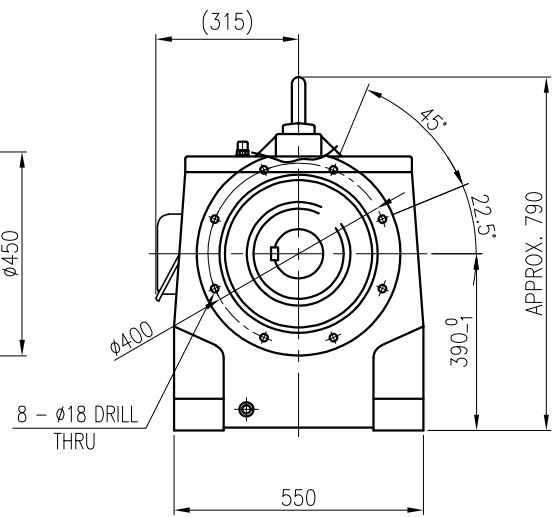
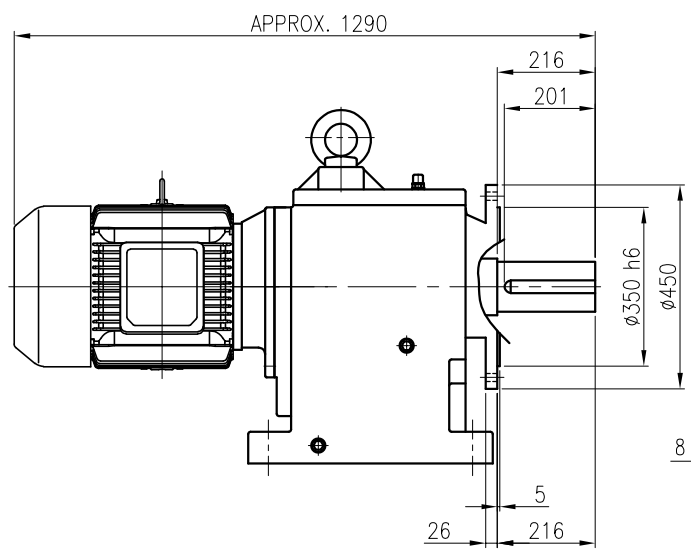

		BEARING				
		INPUT SHAFT	6310ZZ	6312ZZ		
OIL SEAL		2ND PINION	6310	NJ310E	OIL : ISO VG 220	
MOTOR SHAFT	D(M) 60 x 82 x 12	3RD PINION	NJ312E	NJ312E	ABOUT 55 l	
OUTPUT SHAFT	D(M) 125 x 200 x 14	OUTPUT SHAFT	22216	22222	WEIGHT 752 kg	

		외형도 OUTLINE DIMENSION									
		DWG No. EK2D007281H0001				UNIT	mm				
						SCALE	1:1				
No.	DATE	DESCRIPTION of REVISION				DESIGNED	CHECKED	REVIEWED	APPROVED	DATE	2018-08-15
A4(210x297mm)	FORM CE-14-0100-444 2013.11.20					2018.10.01	2018.10.01	2018.10.01	2018.10.01	REVISION No.	01
TYPE						HFM39_180M(18.5kW/22kW)_60~80:1_Ntype				최성민	문병선
		REF. No.	(GKDS477G03)						(A)		

이 도면상에 표시된 정보는 표상중공명(주)의 소유이며 당사의 사전 서면동의 없이 무단사용을 금합니다.