

OUTPUT SHAFT
(28 x 16 x 187)

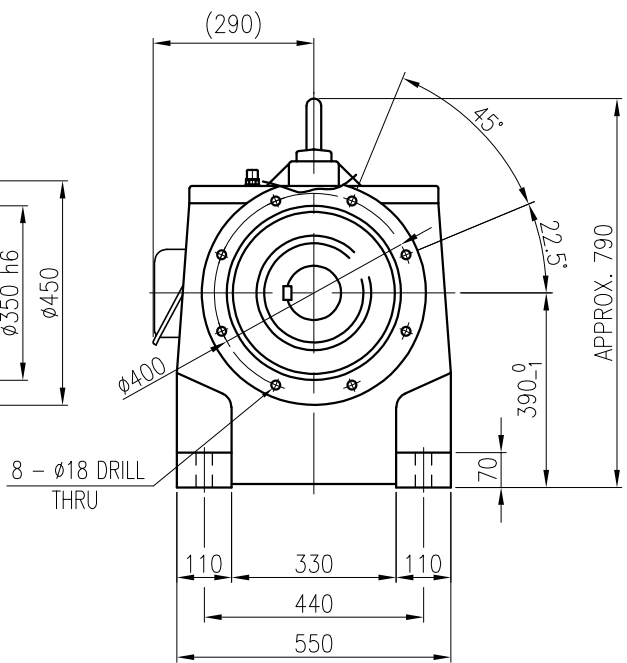
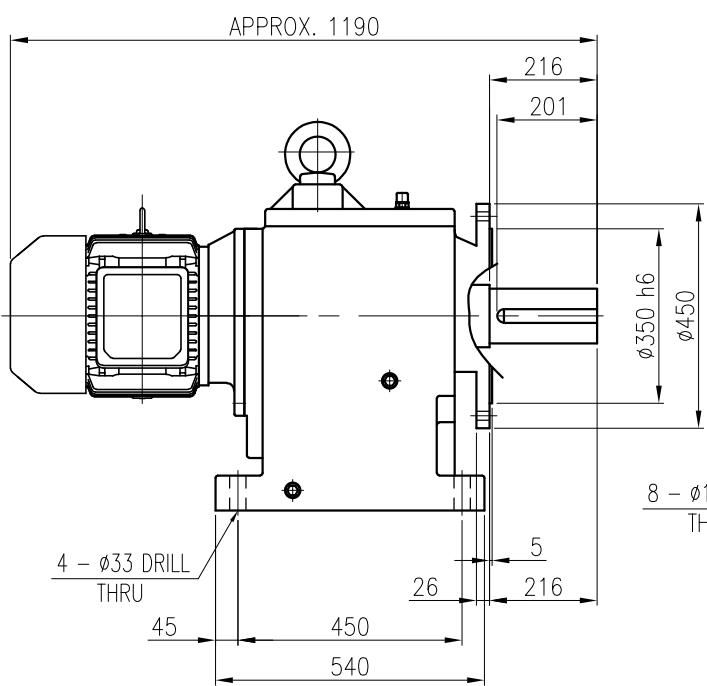

		BEARING				
		INPUT SHAFT	6309ZZ	6310ZZ		
OIL SEAL		2ND PINION	6310	NJ310E	OIL : ISO VG 220	
MOTOR SHAFT	D(M) 50 x 72 x 12	3RD PINION	NJ312E	NJ312E	ABOUT 55 l	
OUTPUT SHAFT	D(M) 125 x 200 x 14	OUTPUT SHAFT	22216	22222	WEIGHT 640 kg	

		외형도 OUTLINE DIMENSION					
		DWG No. EK2D007279H0001				UNIT	mm
						SCALE	1:1
No.	DATE	DESCRIPTION of REVISION				DESIGNED	CHECKED
						REVIEWED	APPROVED
						DATE	2018-08-15
FORM CE-14-0100-4A4 2013.11.20						2018.10.01	2018.10.01
TYPE						HFM39_160M(11kW)_90~120:1_Ntype	
		REF. No.				(GKDS477G01)	
						THIRD ANGLE PROJECTION	
						(A)	

이 도면상에 표시된 정보는 호성중공업(주)의 소유이며 당사의 사전 서면동의 없이 무단사용을 금합니다.