

1	2	3	4	5				
No.	NAME	MATERIAL	DWG/MATL No.	CODE	Q'TY	SIZE	WEIGHT	REMARK
					0			

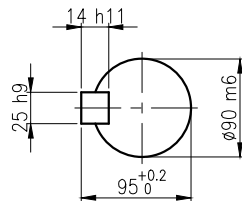
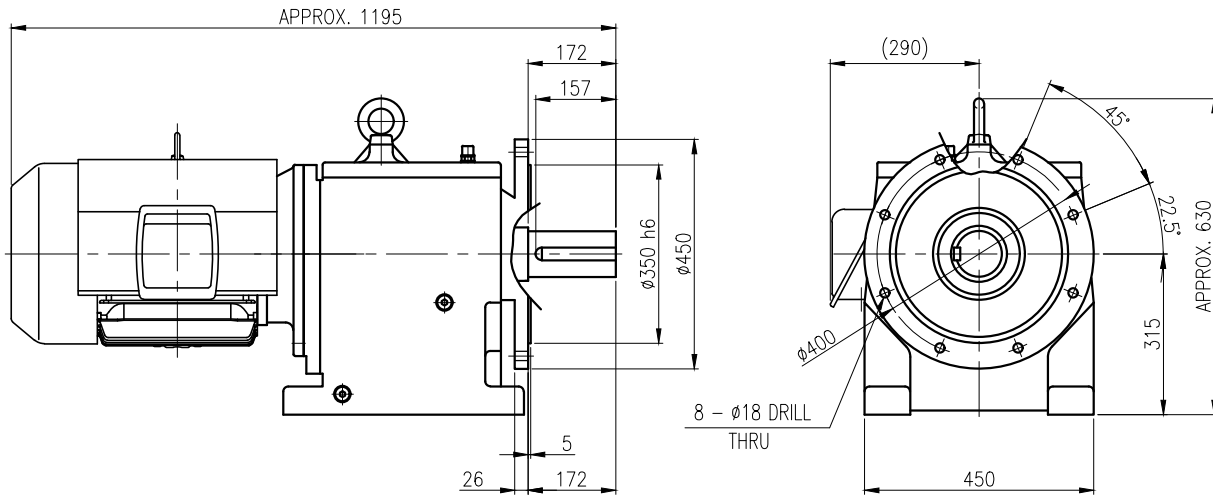

OUTPUT SHAFT
(25 x 14 x 144)

		BEARING				
		INPUT SHAFT	6310ZZ	6312ZZ		
OIL SEAL		2ND PINION	6308	NJ308E	OIL : ISO VG 220	
MOTOR SHAFT	D(M) 60 x 82 x 12	3RD PINION	NJ310E	NJ310E	ABOUT 22 l	
OUTPUT SHAFT	D(M) 105 x 160 x 14	OUTPUT SHAFT	22212	22218	WEIGHT 552 kg	

		외형도 OUTLINE DIMENSION					
		DWG No. EK2DO07268W0001				UNIT	mm
						SCALE	1:1
No.	DATE	DESCRIPTION of REVISION				DESIGNED	2018-08-15
		2018.10.01	2018.10.01	2018.10.01	2018.10.01	DATE	2018-08-15
		최성민	문병선	박희성	홍원철	REVISION No.	01
						THIRD ANGLE PROJECTION	
A4(210x297mm) FORM CE-14-0100-444 2013.11.20		HYOSUNG HEAVY INDUSTRIES				REF. No.	(GKDS476G04)
		TYPE HFM32_180M(18.5kW/22kW)_40~50:1_Ntype				A	

이 도면상에 표시된 정보는 호성중공업(주)의 소유이며 당사의 사전 서면동의 없이 무단사용을 금합니다.