

**OUTPUT SHAFT**  
(25 x 14 x 144)

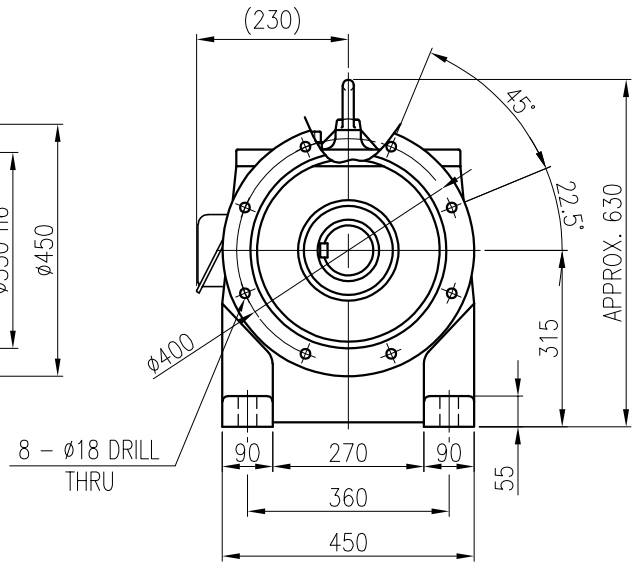
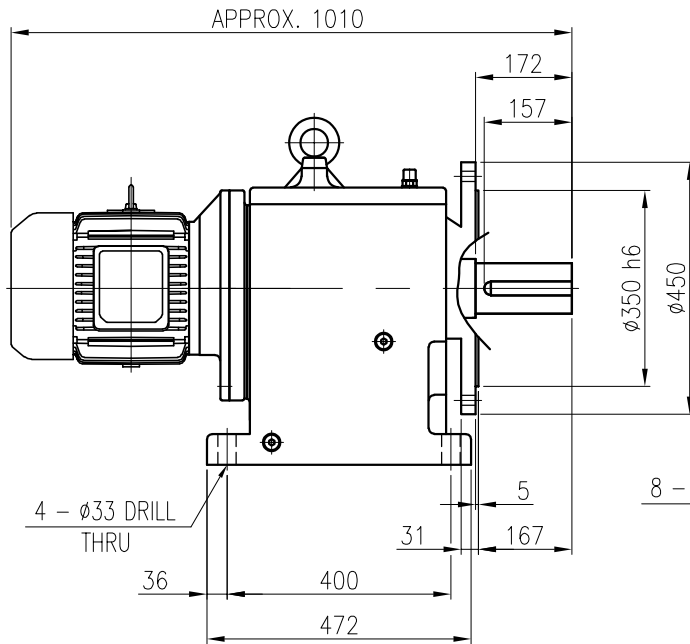

		BEARING				
		INPUT SHAFT	6207ZZ	6308ZZ		
OIL SEAL		2ND PINION	6308	NJ308E	OIL : ISO VG 220	
MOTOR SHAFT	D(M) 40 x 62 x 11	3RD PINION	NJ310E	NJ310E	ABOUT 22 l	
OUTPUT SHAFT	D(M) 105 x 160 x 14	OUTPUT SHAFT	22212	22218	WEIGHT	420 kg

		외형도 OUTLINE DIMENSION					
		DWG No. EK2D007265H0001				UNIT	mm
						SCALE	1:1
No.	DATE	DESCRIPTION of REVISION				DESIGNED	2018-08-15
		2018.10.01	2018.10.01	2018.10.01	2018.10.01	REVISION No.	01
		최성민	문병선	박희성	홍원철	THIRD ANGLE PROJECTION	
		TYPE HFM32_132M(7.5kW)_80~120:1_Ntype				REF. No.	(GKDS476G01)
						A	

이 도면상에 표시된 정보는 호성중공업(주)의 소유이며 당사의 사전 서면동의 없이 무단사용을 금합니다.