

INPUT SHAFT
(10x8x70)

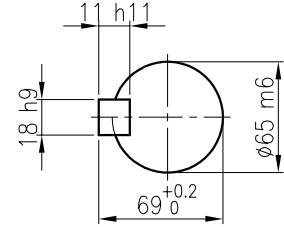

OUTPUT SHAFT
(18x11x113)

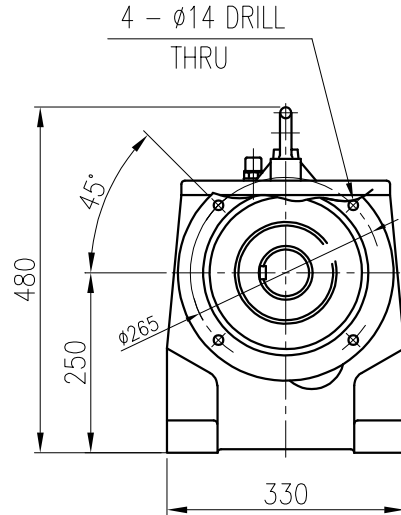
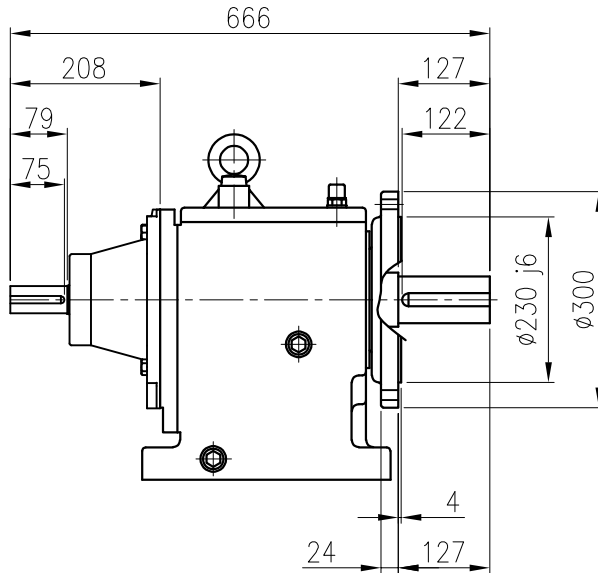

BEARING			
INPUT SHAFT	6308ZZ	6308ZZ	
2ND PINION	6404	NJ306E	
3RD PINION	NJ308E	NJ308E	
OUTPUT SHAFT	22209	22213	

OIL SEAL		2ND PINION	6404	NJ306E	OIL : ISO VG 220
MOTOR SHAFT	D(M) 40 x 90 x 10	3RD PINION	NJ308E	NJ308E	ABOUT 10 l
OUTPUT SHAFT	D(M) 75 x 120 x 12	OUTPUT SHAFT	22209	22213	WEIGHT 155 kg

No.		DATE	DESCRIPTION of REVISION	DWG NAME				UNIT	mm
				외형도 OUTLINE DIMENSION				SCALE	1:1
				DWG No.	EK2D007247H0001			DATE	2018-08-15
				DESIGNED	CHECKED	REVIEWED	APPROVED	REVISION No.	01
				2018.10.01	2018.10.01	2018.10.01	2018.10.01	THIRD ANGLE PROJECTION	
				최성민	문병선	박희성	홍원철		
TYPE HF25_112M(3.7KW)_80~120:1_N type				REF. No.	(GKDS482)			(A)	

The information written in this drawing is HYOSUNG HEAVY INDUSTRIES's property, and may not be disclosed and/or reproduced without the prior official permission of HYOSUNG HEAVY INDUSTRIES Corp.

이 도면상의 표시된 정보는 호성중공업(주)의 소유이며 당사원의 사전 서면동의 없이 무단사용을 금합니다.