

1	2	3	4	5				
No.	NAME	MATERIAL	DWG/MATL No.	CODE	Q'TY	SIZE	WEIGHT	REMARK
					0			

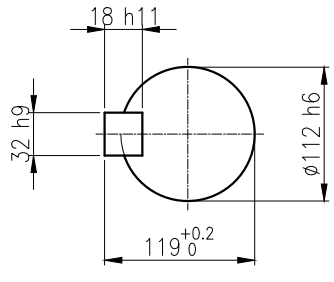
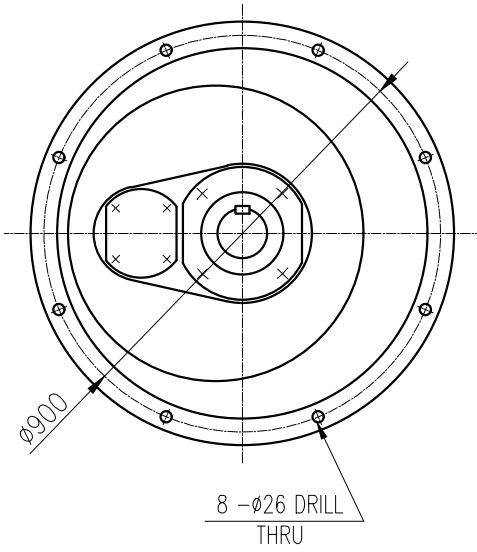
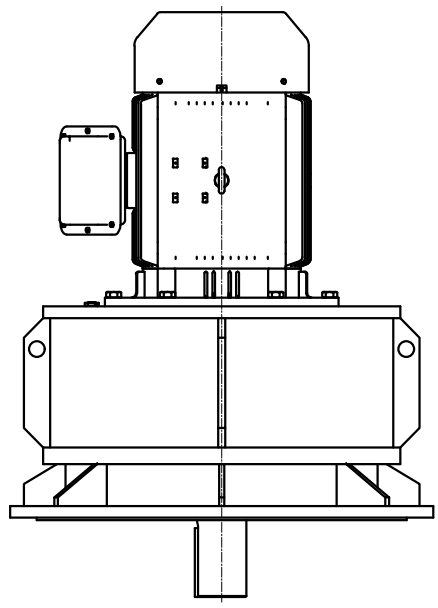
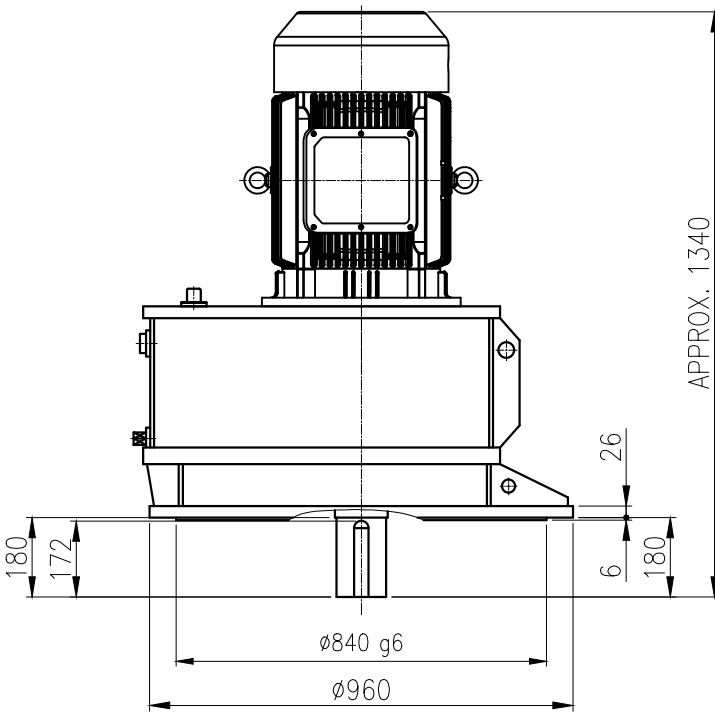

OUTPUT SHAFT
KEY 32 x 18 x 155

		BEARING			
		INPUT SHAFT	6312ZC3	6315ZZ	
OIL SEAL		2ND PINION	30313	30215	OIL : ISO VG 220
MOTOR SHAFT	D(M) 70 x 95 x 13	3RD PINION	-	-	ABOUT 84 l
OUTPUT SHAFT	D(M) 120 x 150 x 14	OUTPUT SHAFT	30220	30224	WEIGHT 1240 kg

		DWG NAME 외형도 OUTLINE DIMENSION			
		DWG No. EK2DO07223H0001		UNIT	mm
				SCALE	1:1
No.	DATE	DESIGNED	CHECKED	REVIEWED	APPROVED
		2018.10.01	2018.10.01	2018.10.01	2018.10.01
		최성민	문병선	박희성	홍원철
DESCRIPTION of REVISION		DATE		2018-08-15	
		REVISION No.		01	
		THIRD ANGLE PROJECTION			
TYPE FVM_200L(45kW)_25~30:1_Ntype		REF. No.		(EN970)	
A4(210X297mm) FORM CE-14-0100-444 2013.11.20				(A)	

The information written in this drawing is HYOSUNG HEAVY INDUSTRIES's property, and may not be disclosed and/or reproduced without the prior official permission of HYOSUNG HEAVY INDUSTRIES Corp.

이 도면상에 표시된 정보는 호성중공업(주)의 소유이며 당사의 사전 서면동의 없이 무단사용을 금합니다.