

	1	2	3	4	5
No.	NAME	MATERIAL	DWG/MATL No.	CODE	Q'TY
					0
				SIZE	WEIGHT
					REMARK

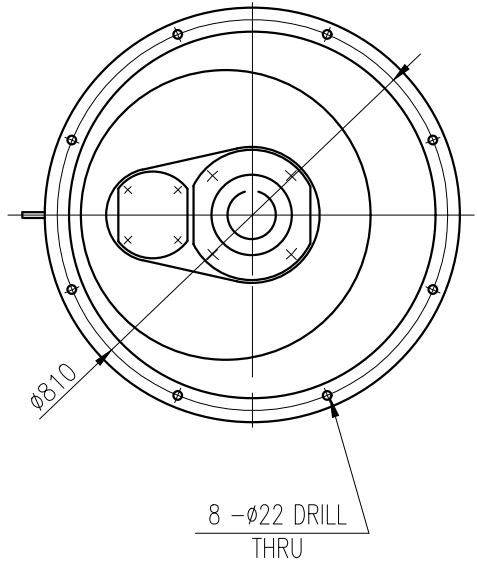

↑
"Q"

VIEW "Q"

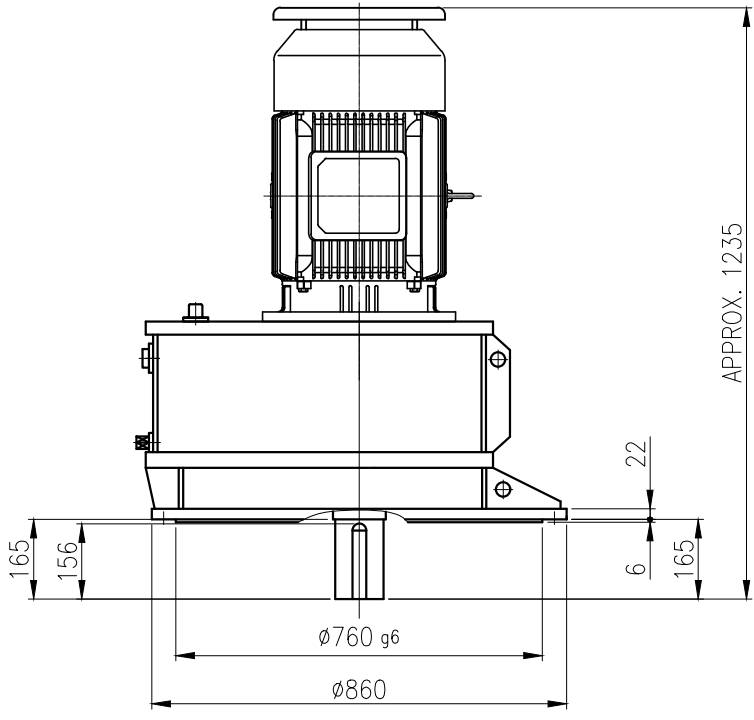
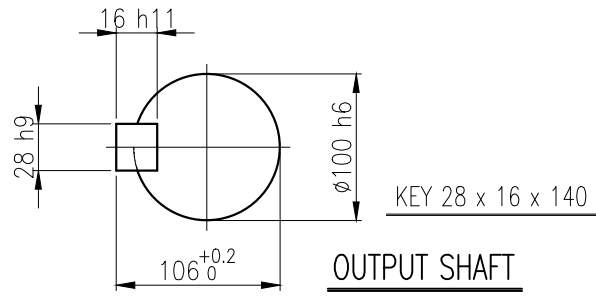

OUTPUT SHAFT

			BEARING		
			INPUT SHAFT	6310ZZ 6311ZZ	
	OIL SEAL		2ND PINION	30311 30213	OIL : ISO VG 220
	MOTOR SHAFT	D(M) 55 x 78 x 12	3RD PINION	-	ABOUT 54 l
	OUTPUT SHAFT	D(M) 110 x 140 x 14	OUTPUT SHAFT	30217 30222	WEIGHT 920 kg

		DWG NAME		외형도 OUTLINE DIMENSION			
		DWG No.		EK2DO07219W0001		UNIT	mm
						SCALE	1:1
No.	DATE	DESCRIPTION of REVISION		DESIGNED	CHECKED	REVIEWED	APPROVED
				2018.10.01	2018.10.01	2018.10.01	2018.10.01
				최성민	문병선	박희성	홍원철
						DATE	2018-08-15
						REVISION No.	01
						THIRD ANGLE PROJECTION	
				REF. No.	(EN966)		(A)

이 도면상에 표시된 정보는 호성중공업(주)의 소유이며 당사의 사전 서면동의 없이 무단사용을 금합니다.