

1	2	3	4	5
No.	NAME	MATERIAL	DWG/MATL No.	CODE Q'TY
				0

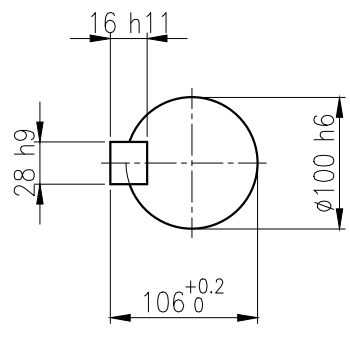

OUTPUT SHAFT
KEY 28 x 16 x 140

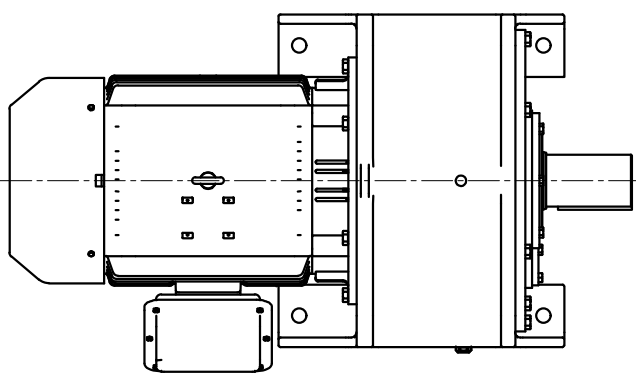
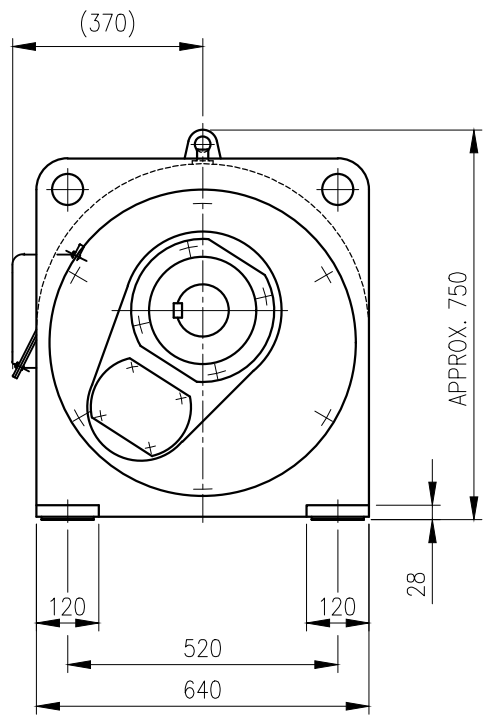
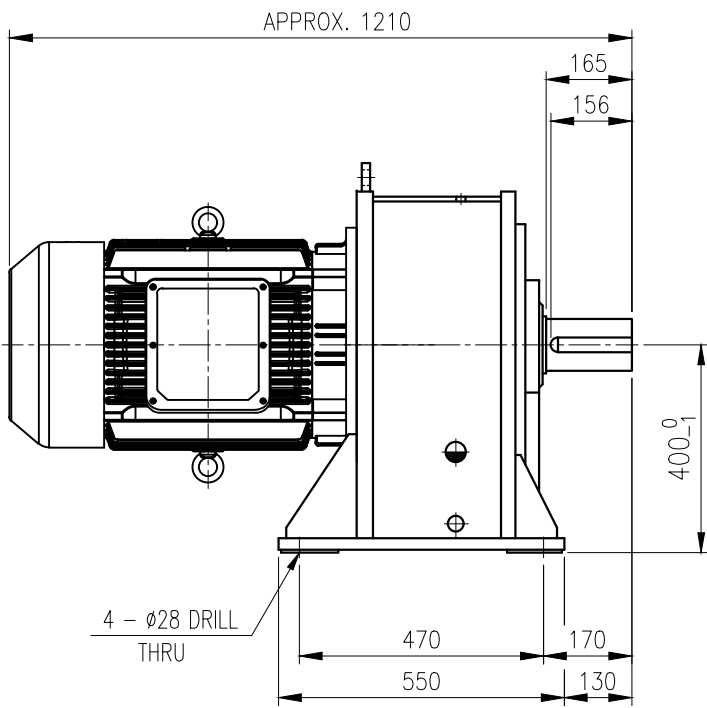

		BEARING			
		INPUT SHAFT	6310ZZ	6313ZZ	
OIL SEAL		2ND PINION	30311	30213	OIL : ISO VG 220
MOTOR SHAFT	D(M) 55 x 78 x 12	3RD PINION	-	-	ABOUT 22 l
OUTPUT SHAFT	D(M) 110 x 140 x 14	OUTPUT SHAFT	30217	30222	WEIGHT 895 kg

		DWG NAME 외형도 OUTLINE DIMENSION			
		DWG No. EK2DO07207H0001		UNIT mm	
				SCALE 1:1	
No.	DATE	DESCRIPTION of REVISION		DESIGNED	CHECKED
				2018.10.01	2018.10.01
				최성민	문병선
				2018.10.01	2018.10.01
				박희성	홍원철
				DATE	2018-08-15
				REVISION No.	01
				THIRD ANGLE PROJECTION	
				REF. No.	(EN948)
				(A)	

이 도면상에 표시된 정보는 호성중공업(주)의 소유이며 당사의 사전 서면동의 없이 무단사용을 금합니다.