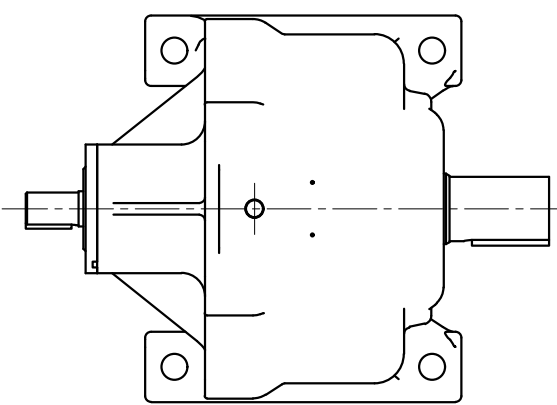
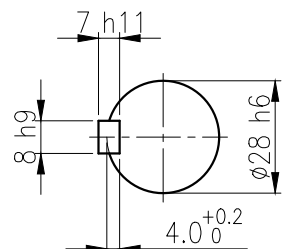
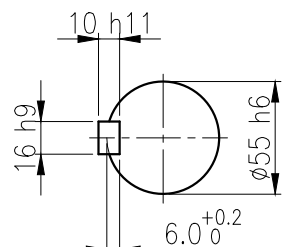
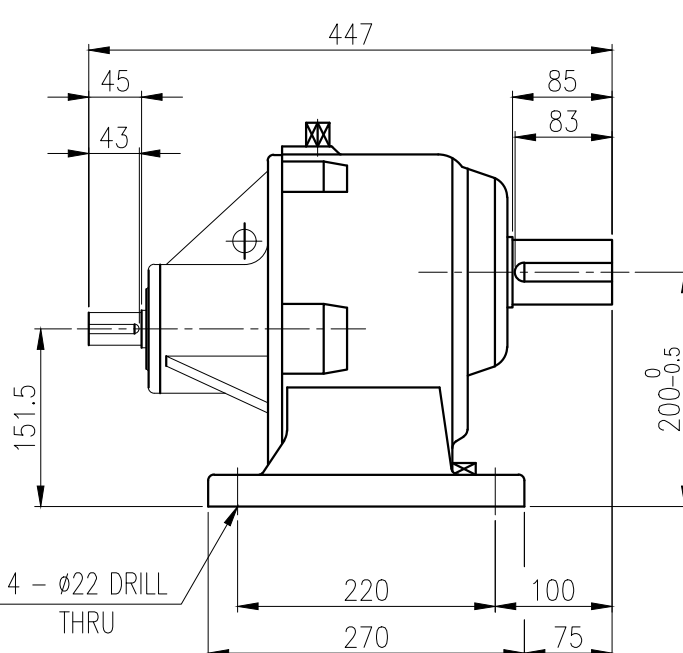
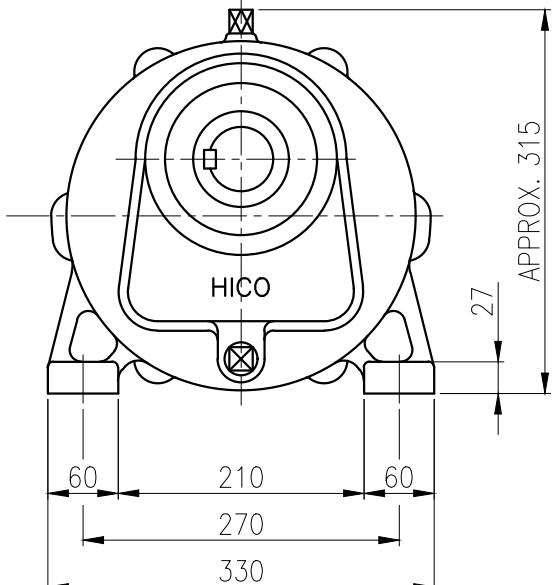

1		2		3		4		5																							
No.	NAME	MATERIAL	DWG/MATL No.	CODE	Q'TY	SIZE	WEIGHT	REMARK																							
					0																										
A					<p>INPUT SHAFT KEY 8 x 7 x 39</p>																										
B					<p>OUTPUT SHAFT KEY 16 x 10 x 75</p>																										
C																															
D	<p>4 - $\phi 22$ DRILL THRU</p>																														
E			<table border="1"> <thead> <tr> <th colspan="2">BEARING</th> </tr> </thead> <tbody> <tr> <td>INPUT SHAFT</td> <td>#6306ZZ #6306ZZ</td> </tr> <tr> <td>2ND PINION</td> <td>#6305ZZ #6305ZZ</td> </tr> <tr> <td>3RD PINION</td> <td>#6306ZZ #5305ZZ</td> </tr> <tr> <td>OUTPUT SHAFT</td> <td>#6312ZZ #PM4020</td> </tr> </tbody> </table>		BEARING		INPUT SHAFT	#6306ZZ #6306ZZ	2ND PINION	#6305ZZ #6305ZZ	3RD PINION	#6306ZZ #5305ZZ	OUTPUT SHAFT	#6312ZZ #PM4020	<table border="1"> <tbody> <tr> <td colspan="2">OIL SEAL</td> <td colspan="2">GREASE : NLGI(EP)00</td> </tr> <tr> <td>MOTOR SHAFT</td> <td>D(M) 30x42x8</td> <td>ABOUT</td> <td>1.8 kg</td> </tr> <tr> <td>OUTPUT SHAFT</td> <td>D(M) 60x82x12</td> <td>WEIGHT</td> <td>62 kg</td> </tr> </tbody> </table>		OIL SEAL		GREASE : NLGI(EP)00		MOTOR SHAFT	D(M) 30x42x8	ABOUT	1.8 kg	OUTPUT SHAFT	D(M) 60x82x12	WEIGHT	62 kg			
BEARING																															
INPUT SHAFT	#6306ZZ #6306ZZ																														
2ND PINION	#6305ZZ #6305ZZ																														
3RD PINION	#6306ZZ #5305ZZ																														
OUTPUT SHAFT	#6312ZZ #PM4020																														
OIL SEAL		GREASE : NLGI(EP)00																													
MOTOR SHAFT	D(M) 30x42x8	ABOUT	1.8 kg																												
OUTPUT SHAFT	D(M) 60x82x12	WEIGHT	62 kg																												
F	<p>FORM CE-14-0100-444 2013.11.20</p> <p>HYOSUNG HEAVY INDUSTRIES</p> <p>TYPE FCB_112Fr(3.7kW)_35~60:1_N type</p>		<p>DWG NAME 외형도 OUTLINE DIMENSION</p> <p>DWG No. EK2DO07199H0001</p> <p>UNIT mm</p> <p>SCALE 1:1</p>		<table border="1"> <thead> <tr> <th>DESIGNED</th> <th>CHECKED</th> <th>REVIEWED</th> <th>APPROVED</th> <th>DATE</th> </tr> </thead> <tbody> <tr> <td>2018.10.01 최성민</td> <td>2018.10.01 문병선</td> <td>2018.10.01 박희성</td> <td>2018.10.01 홍원철</td> <td>2018-08-15</td> </tr> </tbody> </table>		DESIGNED	CHECKED	REVIEWED	APPROVED	DATE	2018.10.01 최성민	2018.10.01 문병선	2018.10.01 박희성	2018.10.01 홍원철	2018-08-15	<p>REVISION No. 01</p> <p>THIRD ANGLE PROJECTION</p>		<p>REF. No. (EN034)</p>	<p>(A)</p>											
DESIGNED	CHECKED	REVIEWED	APPROVED	DATE																											
2018.10.01 최성민	2018.10.01 문병선	2018.10.01 박희성	2018.10.01 홍원철	2018-08-15																											
<p>The information written in this drawing is HYOSUNG HEAVY INDUSTRIES's property, and may not be disclosed and/or reproduced without the prior official permission of HYOSUNG HEAVY INDUSTRIES Corp.</p>																															

이 도면상에 표시된 정보는 호성중공업(주)의 소유이며 당사의 사전 서면동의 없이 무단사용을 금합니다.