

1	2	3	4	5				
No.	NAME	MATERIAL	DWG/MATL No.	CODE	Q'TY	SIZE	WEIGHT	REMARK
					0			

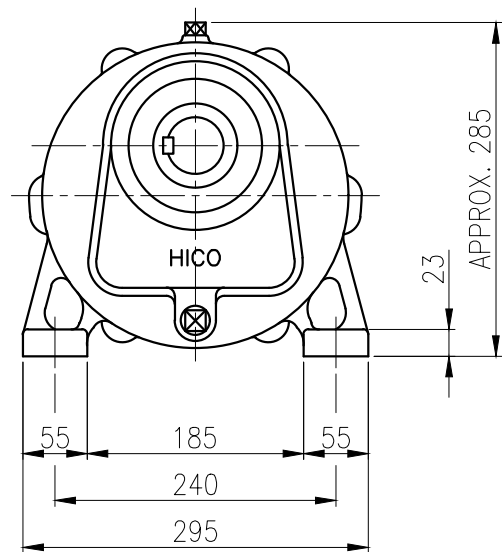
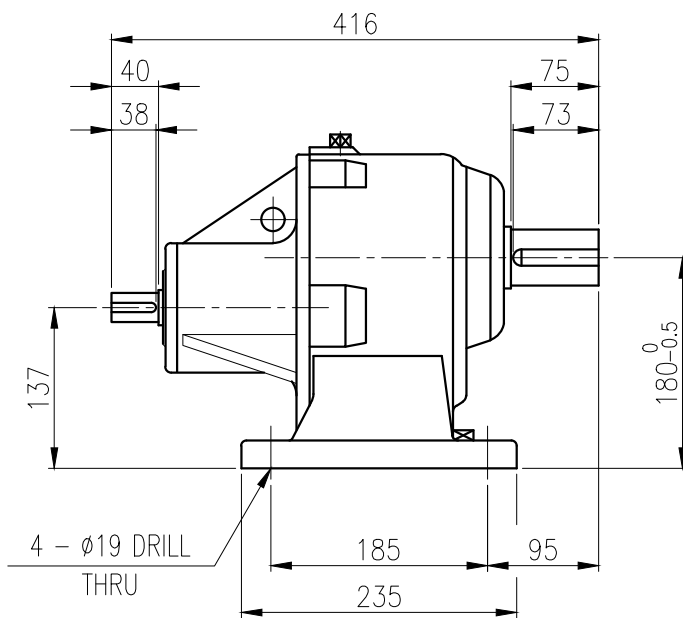
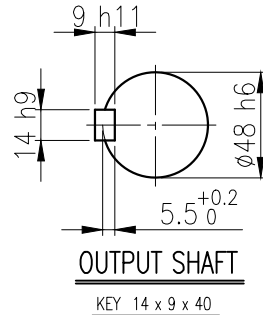
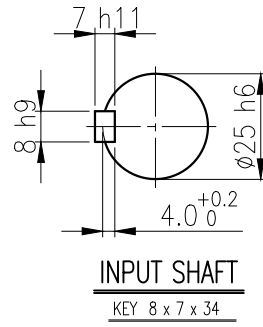
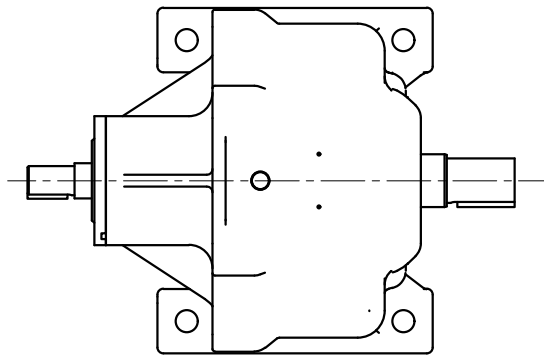

		BEARING		
		INPUT SHAFT	#6306ZZ #6306ZZ	
	OIL SEAL	2ND PINION	#6304ZZ #6304ZZ	GREASE : NLGI(EP)00
	MOTOR SHAFT D(M) 30x42x8	3RD PINION	#6305ZZ #6305ZZ	ABOUT 1.2 kg
	OUTPUT SHAFT D(M) 50x72x12	OUTPUT SHAFT	#6310ZZ #PM4020	WEIGHT 47 kg

		외형도 OUTLINE DIMENSION							
		DWG No. EK2DO07173H0001		UNIT	mm				
				SCALE	1:1				
No.	DATE	DESCRIPTION of REVISION		DESIGNED	CHECKED	REVIEWED	APPROVED	DATE	2018-08-15
A4(210X297mm)	FORM CE-14-0100-444 2013.11.20			2018.10.01 최성민	2018.10.01 문병선	2018.10.01 박희성	2018.10.01 홍원철	REVISION No.	01
TYPE				FCC_100Fr(2.2kW)_40~60:1_N type		THIRD ANGLE PROJECTION			
		REF. No.	(EN032)			(A)			

The information written in this drawing is HYOSUNG HEAVY INDUSTRIES's property, and may not be disclosed and/or reproduced without the prior official permission of HYOSUNG HEAVY INDUSTRIES Corp.

이 도면상에 표시된 정보는 호성중공업(주)의 소유이며 당사의 사전 서면동의 없이 무단사용을 금합니다.