

1	2	3	4	5				
No.	NAME	MATERIAL	DWG/MATL No.	CODE	Q'TY	SIZE	WEIGHT	REMARK
					0			

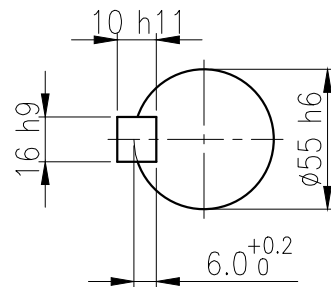
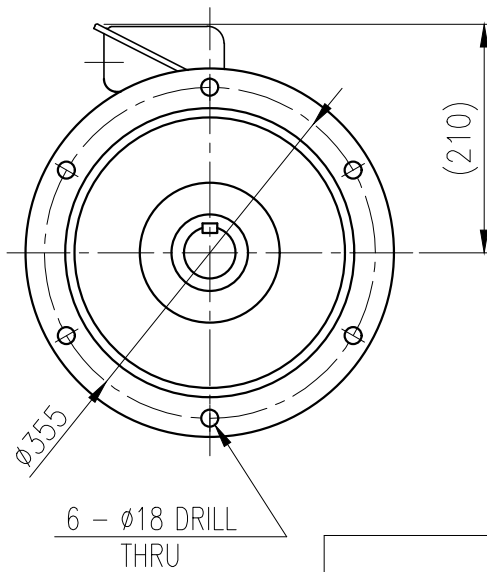
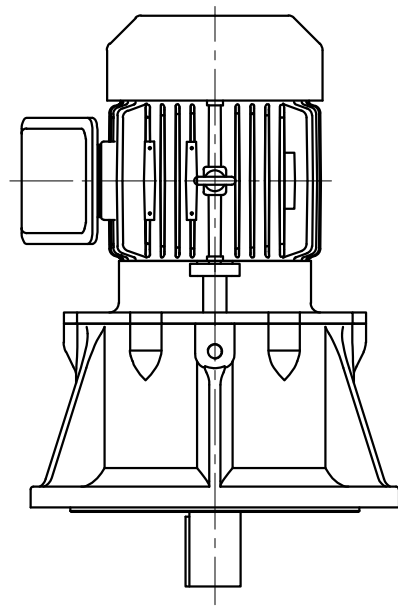
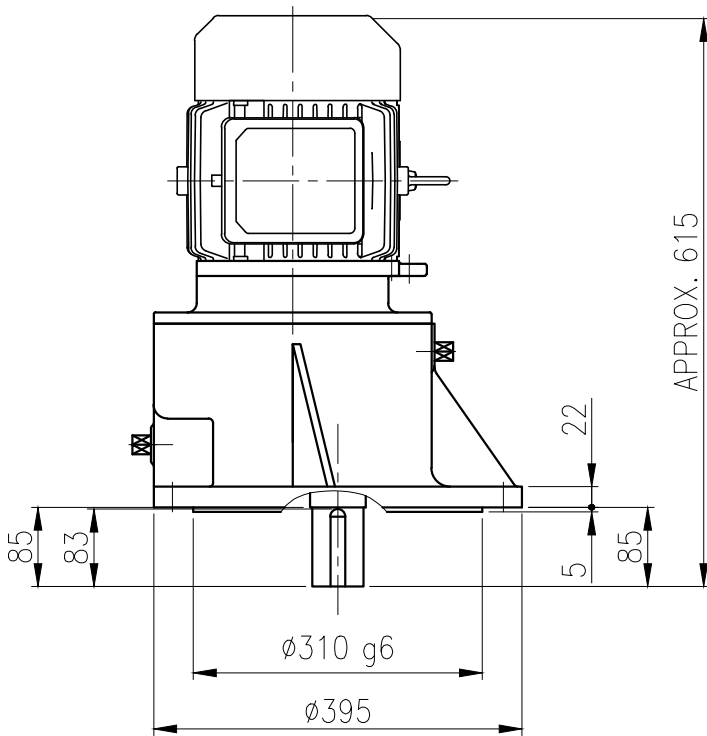

OUTPUT SHAFT
KEY 16 x 10 x 75

		BEARING			
OIL SEAL		INPUT SHAFT	#6206ZZ	#6307ZZ	
MOTOR SHAFT D(M) 28 x 40 x 8		2ND PINION	#6305ZZ	#6305ZZ	GREASE : NLGI(EP)00
OUTPUT SHAFT D(M) 60 x 82 x 12		3RD PINION	#6306ZZ	#5305ZZ	ABOUT 1.8 kg
		OUTPUT SHAFT	#6312ZZ	#PM4020	WEIGHT 122 kg

		외형도 OUTLINE DIMENSION				DWG NAME	
		EYK2DO07163H0001				UNIT	mm
						SCALE	1:1
No.	DATE	DESCRIPTION of REVISION				DESIGNED	2018-08-15
A4(210X297mm)	FORM CE-14-0100-444 2013.11.20					2018.10.01	2018-08-15
TYPE						FVC_112Fr(3.7kW)_40~60:1_N type	REVISION No.
						THIRD ANGLE PROJECTION	
						REF. No.	(EN217)
						(A)	

The information written in this drawing is HYOSUNG HEAVY INDUSTRIES's property, and may not be disclosed and/or reproduced without the prior official permission of HYOSUNG HEAVY INDUSTRIES Corp.

이 도면상에 표시된 정보는 호성중공업(주)의 소유이며 당사의 사전 서면동의 없이 무단사용을 금합니다.