

1	2	3	4	5				
No.	NAME	MATERIAL	DWG/MATL No.	CODE	Q'TY	SIZE	WEIGHT	REMARK
					0			

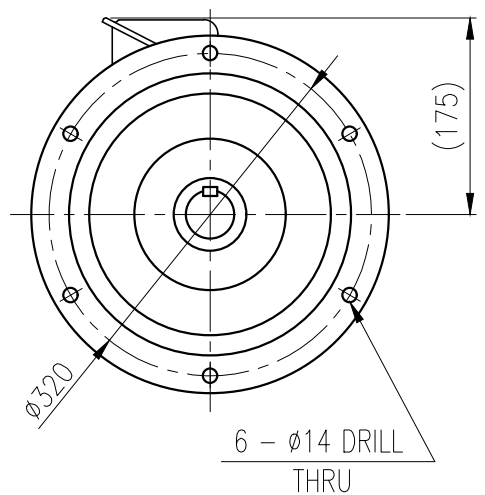

VIEW "Q"

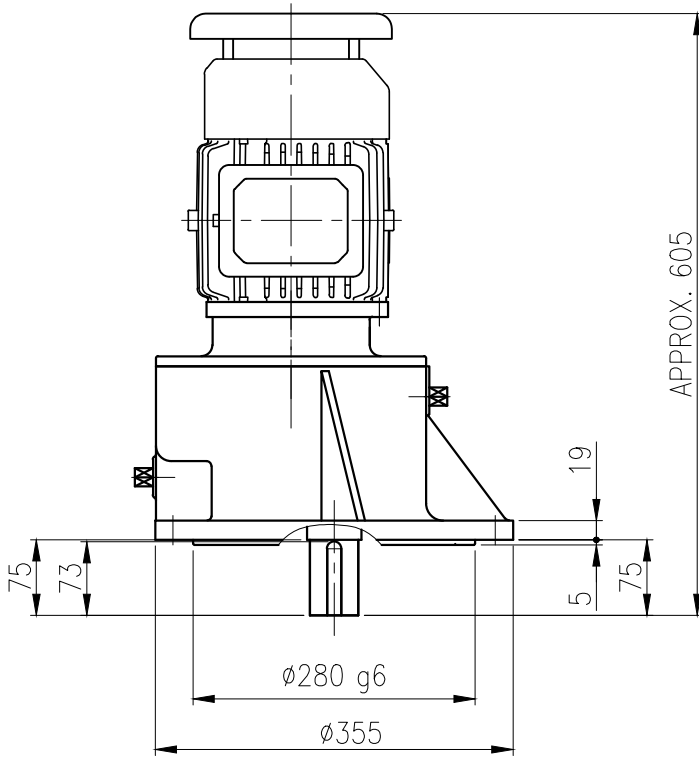
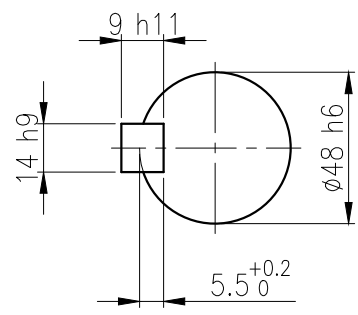
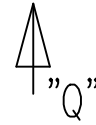

OUTPUT SHAFT

KEY 14 x 9 x 66

		BEARING			
		INPUT SHAFT	#6204ZZ	#6305ZZ	
OIL SEAL		2ND PINION	#6302ZZ	#6304ZZ	GREASE : NLGI(EP)00
MOTOR SHAFT	D(M) 22 x 35 x 8	3RD PINION	#6305ZZ	#6305ZZ	ABOUT 1.2 kg
OUTPUT SHAFT	D(M) 50 x 72 x 12	OUTPUT SHAFT	#6310ZZ	#PM4020	WEIGHT 76 kg

		DWG NAME 외형도 OUTLINE DIMENSION							
		DWG No. EK2DO07157W0001		UNIT mm					
				SCALE 1:1					
No.	DATE	DESCRIPTION of REVISION		DESIGNED	CHECKED	REVIEWED	APPROVED	DATE	2018-08-15
A4(210x297mm)	FORM CE-14-0100-444 2013.11.20			2018.10.01 최성민	2018.10.01 문병선	2018.10.01 박희성	2018.10.01 홍원철	REVISION No.	01
TYPE FVC_90Fr(1.5kW)_75~90:1_N type				REF. No.	(EN214)		THIRD ANGLE PROJECTION		

이 도면상에 표시된 정보는 호성중공업(주)의 소유이며 당사의 사전 서면동의 없이 무단사용을 금합니다.