

OUTPUT SHAFT

KEY 14 x 9 x 40

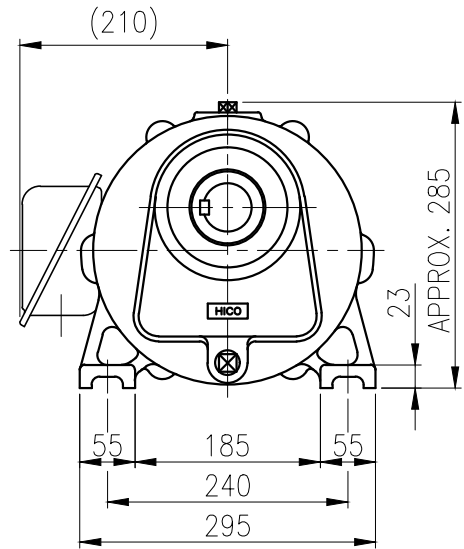
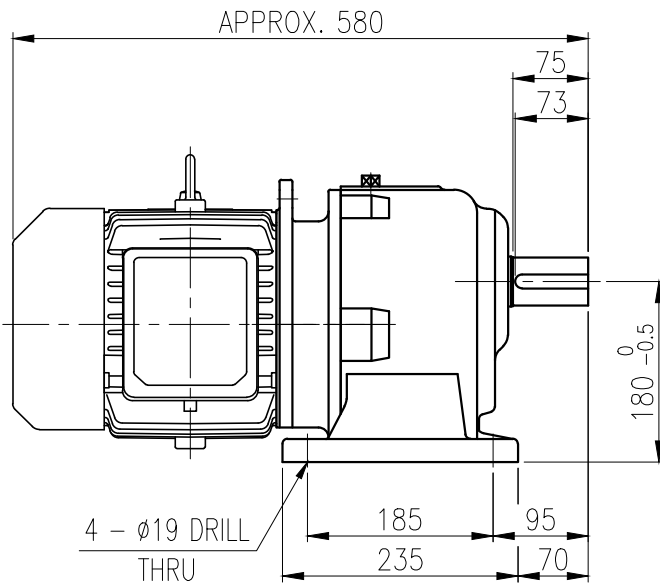

		BEARING				
		INPUT SHAFT	#6206ZZ	#6306ZZ		
OIL SEAL		2ND PINION	#6304ZZ	#6304ZZ	GREASE : NLGI(EP)00	
MOTOR SHAFT	D(M) 24x40x8	3RD PINION	#6305ZZ	#6305ZZ	ABOUT	1.2 kg
OUTPUT SHAFT	D(M) 50x72x12	OUTPUT SHAFT	#6310ZZ	#PM4020	WEIGHT	94 kg

		DWG NAME				외형도 OUTLINE DIMAENSION					
		DWG No. EK2D007116H0001				UNIT	mm				
						SCALE	1:1				
No.	DATE	DESCRIPTION of REVISION				DESIGNED	CHECKED	REVIEWED	APPROVED	DATE	2018-08-15
A4(210x297mm)	FORM CE-14-0100-444 2013.11.20					2018.10.01	2018.10.01	2018.10.01	2018.10.01	REVISION No.	01
TYPE						RPH_112Fr(3.7kW)_40~60:1_N type				REF. No.	(EN252)

이 도면상에 표시된 정보는 표상용이며 (주)의 소유이며 영사의 사전 서면동의 없이 무단사용을 금합니다.